

THANKS FOR PURCASHING OUR PRODUCT

WP – 120A

INVERTER PLASMA CUTTING MACHINE



WEIRO

OPERATION MANUAL

(Read the manual carefully before installation, operation and maintenance)

Safety Depends on You

WEIRO are welding and cutting equipment is designed and built with safety in mind. However, your overall safety can be increased by proper installation... and thoughtful operation in your part. DO NOT INSTALL, OPERATE OR REPAIR THIS EQUIPMENT WITHOUT READING THIS MANUAL AND THE SAFETY PRECAUTIONS CONTAINED THROUGHOUT. And, most importantly, think before you act and be careful.

CV. ANUGRAH DUTA NIAGA

Jln. Arief Rahman Hakim 51 Komplek Ruko 21 Klampis Blok D-1

Telp. 031 – 5990089, 5997259 (Hunting)

Fax. 031 – 5966099

Email : adn_office@yahoo.com

Index

1. Principle	&Technical
data.....(1)	
2. Features	&
Applications.....(5)	
3. Installation	
Guide.....(6)	
4. Operating	
Instruction(9)	
5. Repair	&
Maintenance.....(12)	

WP 120A Block diagram of principle

Figure 1: Block diagram of principle

This series of cutting machines applies IGBT Middle Frequency inverter technology. Line frequency 3-phase input volt are rectified by rectifier, inverted into MF AC by IGBT components, insulated by MF transformer, rectified and filtered by MF rectifier, then outputs DC power suitable for cutting. After this process, the cutter's dynamically responsive speed has been greatly increased, so the transformer and reactor size and weight are reduced noticeably, thus achieving energy-saving.

Power sources enjoy sound drooping outer ability and anti-fluctuating ability due to loop control of reasonable logic circuit design. First, the signals of the set parameters transmit into set circuit to adjust output current. Secondly, the feedback circuit amplifies output current to get feedback signal. PWM circuit compares the set signals with feedback signals to determine output pulse width. Finally, driving circuit will control pulse to amplify power to drive IGBT. Meanwhile, protection circuit monitor over-current, low-voltage and overheat phenomenon to ensure reliable cutting. Because of reasonable sequence of logic control, the cutters can perform pre-gas flow, HF arc start, cutting and post-gas flow convenient for operators.

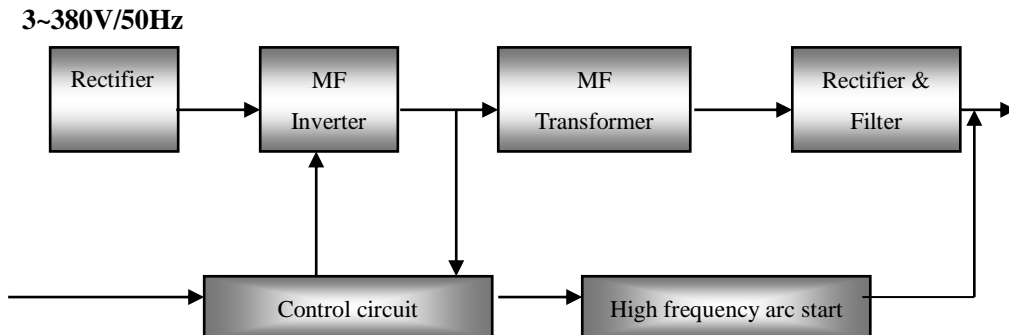
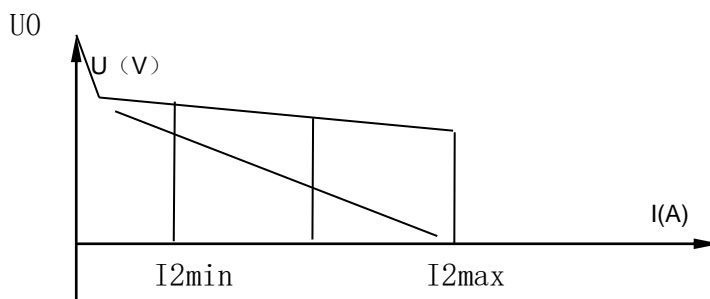

Figure 2: Model WP 120A Volt-Ampere curve

1. Main technical parameters

Items	Model	WP120A
Input volt (V)		Three phase 380 / 50Hz
Rated input capacity (KVA)		25.7
Rated input current (A)		37
Range of output current (A)		30—120
Open load (V)		345
Rated load volt (V)		128
Rated duty cycle		60%
Air pressure for cutting torch (MPa)		0.45
Gas flow rate (L/min)		250
Max cutting thickness for carbon steel (mm)		35
Optimum cutting thickness for carbon steel		1-30
Dimension		576×297×557
Weight (Kg)		43.5
Insulated class of main transformer		H
Insulated class of output reactor		B

Table 1: Parameter Specification

3.Main components list

- WP120A

No	Name	Model	Remark
K1	Circuit breaker	DZ47-63D (40A/3P)	
D1	Three-phase rectified module	MDS100A-1200V (big)	
R1	Varistor	MYL1 625/5	
V1~2	IGBT module	SKM100GB128D	
C5	Polypropylene capacitor	MFD-DA01 4uF/500VAC	
IGBTZRB	IGBT protection Board	NBC-500 II .5.1.0	
T1	Main transformer	LGK-100.3.1.0	
D2	Fast recovery diode module	DWC2F100N060S	
D3	Fast recovery diode module	DWC2F100P060S	
L2	Current exchange inductor	ZX7-400III.5.2.0	
T4	Transformer for ZKB/QDB	ATIG-500.3.1-8	
F1	Fuse	2A (5×20)	
M	Fan	AK2072HB	220V single phase
SW	Thermal switch	JUC-6F 70°C (close)	
QDB	Drive board	ZX7-400III.7.0	
ZKB	Main control board	LGK-100.6.0	
DF	Electromagnet valve	DF2-5(0.8MPa)	AC36
	Switch	KCD4-202	
	Potentiometer	WH118-2W-4.7KΩ	Adjusting ampere

Table 2: Main Components List of WP 100A / 120A

This series inverter air plasma cutting machines, which are new-designed for metal processing, apply IGBT as well as PWM (Pulse width Modulation) soft switch technology. This series cutting machines can cut all types of metal materials, especially for high alloy steel and non-ferrous metals that can not be cut by using flame cutting machine. This series cutting machines enjoys reasonable static characteristic and sound dynamic characteristic, can perform HF arc start.

Features and benefits:

- HF inverter, small size, light weight.
- Soft switch transform, high efficiency.
- Delayed post-flow can protect plasma torch effectively.
- Outstanding cutting quality with trim and slick edge.
- Short-circuit protection inside cutting torch.
- HF arc-starting, easy to strike.
- Non-source power factor compensation technology, high PF.
- 2 cycle / 4cycle operating modes provided.
- Thermal protection provided.

Applications:

- Suitable for cutting mild steel, alloy steel, stainless steel, Copper, Aluminum and other non-ferrous metals.

This series cutting machines manufacturing strictly comply with National standard GB15579.1-2004<<"Arc welding equipment" Chapter one: Welding Power Source>>

1. Pre-installation

1.1 Installation Environment

The WP series is designed for use in adverse environments. Examples of environments with increased adverse conditions are:

- In locations in which freedom of movement is restricted, so that the operator is forced to perform the work in a cramped (kneeling, sitting or lying) position with physical contact with conductive parts;
- In locations which are fully or partially limited by conductive elements, and in which there is a high risk of unavoidable or accidental contact by the operator;
- In wet or damp hot locations where humidity or perspiration considerably reduces the skin resistance of the human body and the insulation properties of accessories.
- Environments with adverse conditions do not include places where electrically conductive parts, in the near vicinity of the operator, which can cause increased hazard, have been insulated.

1.2. Installation Location

Be sure to locate the welder according to the following guidelines:

- · In areas, free from moisture and dust.
- · Ambient temperature between 0 degrees C to 40 degrees C.
- · In areas, free from oil, steam and corrosive gases.
- · In areas, not subjected to abnormal vibration or shock.
- · In areas, not exposed to direct sunlight or rain.
- · Place at a distance of 12" (304.79mm) or more from walls or similar boundaries that could restrict natural airflow for cooling.

1.3 Power Source Connections

Warning

Thermal Arc advises that this equipment be electrically connected by a qualified electrician.

ELECTRIC SHOCK can kill; SIGNIFICANT DC VOLTAGE is present after removal of input power.

DO NOT TOUCH live electrical parts.

- SHUT DOWN welding power source, disconnect input power employing lockout/tagging procedures.
- Lockout/tagging procedures consist of padlocking line disconnect switch in open position.
- Removing fuses from fuse box, or shutting off and red-tagging circuit breaker or other disconnecting device.

1.4. Power Supplier Requirement

- Input volt must be standard sine wave, effective value 380V, frequency 50Hz.
- Unbalance degree of 3-phase volt must be no more than 5%.
- Power supply

Product type		WP120A
Power supply		3 phase AC380V/50Hz
Min. capacity	Power network	38.5 KVA
	Generator	51.4 KVA
Input volt protection	Fuse	50 A
	Circuit breaker	63 A
Cable size (cross-section)	Input volt	4 mm ²
	Output volt	15 mm ²
	Ground lead	4 mm ²

Table 3: Power supply connection

Note: The sizes of fuse and breaker in the table are for reference only.

4. Installation:

This series of cutter is small, light and portable. They will be more convenient when being placed on the trolleys. Ensure the location where the cutter is to be placed is even.

ACUT series of cutters wire diagram as Figure 5:

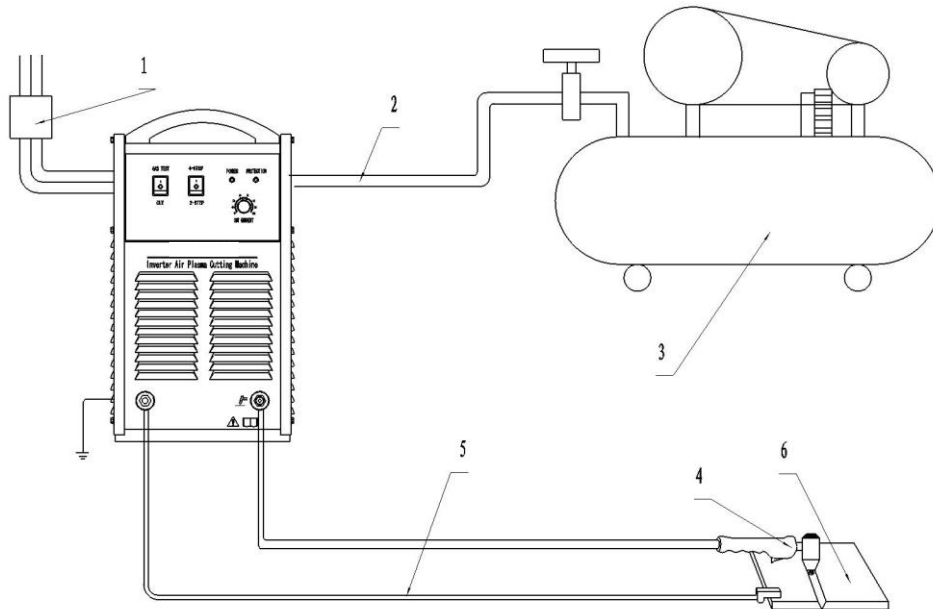

Figure 4: Connection Chart for WP series

1. 3-phase 380V power source
2. Gas hose
3. Air compressor
4. Cutting torch
5. Output cable
6. Workpiece

The max gas pressure of optional air compressor should be 0.8 Mpa and gas flow rate be no less than 250L/min. Connect air compressor to inlet of air gauge on the rear panel of cutter. Turn on air compressor to let gas pressure climb up to proper value for cutting. Then turn on air switch on the rear panel of the cutter.

1. Functional introduction

1.1 Front panel illustration and parts number reference

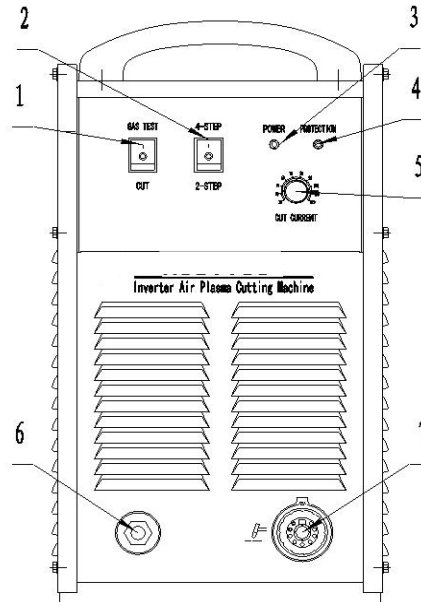

Figure 5: Front panel

1. “Gas test / Cutting” switch

Switch to “Gas test”, check if gas flow is normal; to “cutting” to perform air plasma cutting.

2. “Auto-lock / Non-auto-lock” switch

Switch to “Non-auto-lock”, perform cutting when pressing torch trigger, stop welding when releasing the trigger. This mode is suitable for short cutting seam. To “Auto-lock”, after successfully starting arc by pressing torch trigger, then you can perform cutting by releasing the trigger. When you press torch trigger again, torch will stop cutting. This mode is suitable for long cutting seam.

3. “Power on / off” indicator

Indicating whether power source is effectively connected to power supply

4. “Protection” indicator lamp

Cutting machine will automatically stop working when it is overheat, and the lamp will light up.

5. “Welding current” regulation knob

Used to adjust cutting current

6. Cable socket

Connect to workpiece

7. Central socket of cutting machine

Connect to cutting torch

1.2 Rear panel illustration and parts number reference

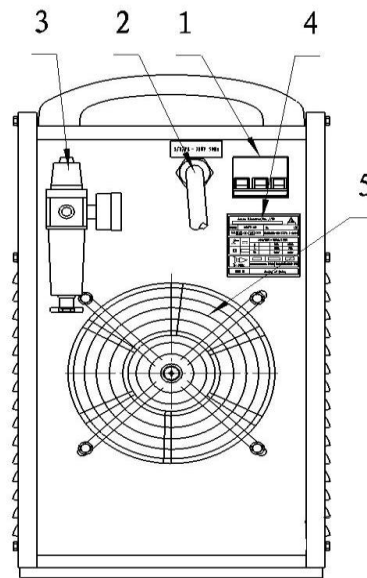

Figure 6: Rear panel

1. Circuit breaker

The function of circuit breaker is to protect cutting machine by automatic trip to turn-off power supply while the machine is overloaded or in failure. Normally, the circuit breaker flipped to upward means power-on. Use switch on the switchboard to start or stop cutting machine, avoiding using the circuit breaker.

2. Input power cable

It is 4-pin cable. The mixed-colored wire must be firmly grounded, the rest wires connect to corresponding 3-phase power supply.

3. Compressed air filter

Connect to air compressor by gas hose for reducing gas pressure and filtering moisture in the air. Adjust the knob to alter the output air pressure of filter, the values of air pressure displaying at the air gauge are normally in the range of 0.6-0.8Mpa. The water accumulated in the water trap should not touch on the filter element. Please let out the accumulated water in time by releasing the valve on the bottom. Otherwise, the accumulated water will enter the cutting torch, thus influencing arc starting and cutting performance.

4. Specification plate

5. Cooling fan

Cool down the heat components in the cutting machine.

2. Operating procedure

2.1 After going through periodical check process, power on the cutting machine, then working indicator will light up and cooling fan will spin.

2.2 Flip the “Gas test/Cutting” switch to “Gas test”.

The gas valve in the machine will turn on and let gas flow up to one minute to remove condensed water drops accumulating in the torch. Regulate the compressed air filter to let the hand of air gauge indicate 0.45 Mpa. Then flip the “Gas test/Cutting” switch to “Cutting”.

2.3 ACUT60 cutting machine applies contact type cutting torch. When cutting, let the nozzle of torches touch workpiece, then press the torch button to start arc.

ACUT100 and ACUT120 cutting machine apply non-contact type cutting torch. When cutting, keep a distance from 3 to 5 mm between nozzle and workpiece to start arc and allow no touch between nozzle and workpiece in the process of cutting.

2.4 Usually, cutting begins at the margin of the workpiece. It can also start at any point of the workpiece, but cutting torch should be tilted a bit to blow molten metal and form the start point of groove.

2.5 While in cutting, keep cutting torch moving at consistent speed.

2.6 While stopping cutting, move the torch away from workpiece after the plasma arc goes out completely. Otherwise the workpiece will be distorted by remained arc.

WARNING: Have a qualified electrician do the maintenance and trouble shooting work. Turn the input power off, using the disconnect switch at the fuse box before working inside the machine.

1. Attentions:

1. When problems such as abnormal cutting seam, arc-interruption, difficult arc-start occurs, please check easy-worn-out consumables like nozzle or electrode and replace them if they are bad consumption.
2. When assembly electrode ,gas diffuser, nozzle and nozzle cover, should aware of fitting up coaxially, nozzle cover press the nozzle toughly.
3. While in cutting, avoid moving cutting torch too quickly in case burning out nozzle due to arc flame rebounding from non-cut-through workpiece base as well as moving too slow to influence cutting quality.
4. While in cutting, please keep air pressure in the range of 0.6 to 0.8Mpa. Let out accumulated water in the compressed air filter timely.
5. The machine equipped with low-voltage protection. The machine will automatic stop working when the input primary power is too low.
6. The machine equipped with overheat protection. The machine will automatic stop working when the temperature inside the machine is very high and the protection lamp on the front panel will light on.

No	Trouble	Causes	What to do
1	Indicator lamp does not light up and machine does not work when switched on.	1)Phase missing 2)Fuse broken (2A) 3)Power cable broken	1)Inspect power source 2)Inspect cooling fan, transformer for ZKB/QDB, and main control board 3)Inspect cable
2	Overheat indicator lamp lights up	1)Too high temperature inside machine 2)Thermal switch is damaged	1)Stop working till machine cools down 2)Change the thermal switch
3	No gas flows out while in gas test.	1)Electromagnet valve is damaged 2) Gas way is blocked 3)“Gas test / Cutting” switch is damaged 4)The output air pressure of air compressed filter is too high.	1)Replace 2)Inspect gas way 3) Replace 4)Regulate pressure knob on the filter to reduce air pressure and release water valve. After air pressure get down, tighten up the valve.
4	The cutting torch’s button does not work.	1)Button is damaged 2)Wire is broken 3)Control board is damaged	1)Replace 2)Connect the broken wire 3) Replace
5	Too wide cut	1)Slow cutting speed 2)Nozzle is burn out	1)Increase cutting speed 2)Replace
6	Non-vertical cut	1)Nozzle is burn out 2)Non-alignment of nozzle to electrode. 3)Tilt cutting torch	1)Replace 2)Align the nozzle and the electrode 3)Adjust the cutting angle.

Table 4: Trouble Shooting Table