

THANKS FOR PURCASHING OUR PRODUCT

# **ARC - 400**

**INVERTER DC MMA WELDING MACHINE**



# **WEIRO**

## **OPERATION MANUAL**

(Read the manual carefully before installation, operation and maintenace)

### **Safety Depends on You**

**WEIRO are welding and cutting equipment is designed and built with safety in mind. However, your overall safety can be increased by proper installation... and thoughtful operation in your part. DO NOT INSTALL, OPERATE OR REPAIR THIS EQUIPMENT WITHOUT READING THIS MANUAL AND THE SAFETY PRECAUTIONS CONTAINED THROUGHOUT. And, most importantly, think before you act and be careful.**

**CV. ANUGRAH DUTA NIAGA**

Jln. Arief Rahman Hakim 51 Komplek Ruko 21 Klampis Blok D-1

Telp. 031 – 5990089, 5997259 (Hunting)

Fax. 031 – 5966099

Email : [adn\\_office@yahoo.com](mailto:adn_office@yahoo.com)

---

## Index

1. Principle & Technical data.....	( 1 )
2. Features & Applications.....	(6)
3. Installation Guide.....	(7)
4. Operating Instruction .....	(10)
5. Repair & Maintenance.....	(13)
Appendix A: EMC Suggestion for installation and use of welder.....	(16)
Appendix B: Feedback Form.....	(19)

*This operating manual can be fit for ARC-E (include ARC-E-315/400/500) series welding machines. The technical data are measured with power supply 3 phase 380V, the data will be changed when you use other input voltage such as 230V, 415V, etc.*

## Principle & Technical data

ARC-E series Block diagram of principle

Input 3-phase 380V/50Hz

Output

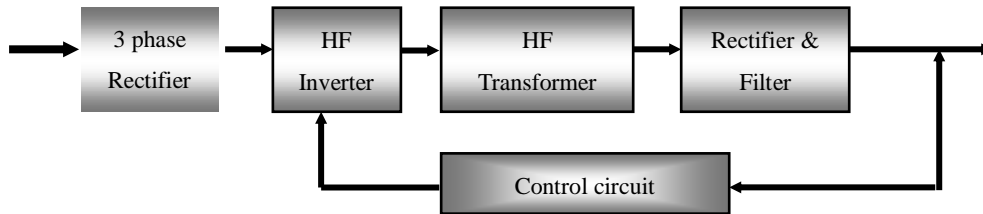

Figure 1: Block diagram of principle

This series welding machines apply IGBT soft switch inverter technology. 3- phase 380V input volt are rectified by rectifier, inverted into HF AC, reduced by HF transformer, rectified and filtered by HF rectifier, then output DC power suitable for welding. After this process, the welder's dynamical responsive speed has been greatly increased, so the welder size and weight are reduced noticeably result in energy saving. Power source enjoy sound anti-fluctuating ability and high-quality performance during external context changes (As to fluctuation in input power supply and extended welding cables). Easy to arc start, stable arc length, pretty weld formation and capability of continuous regulation of welding current and arc force current. Inverter DC arc welding machines output characteristic curve is as follows:

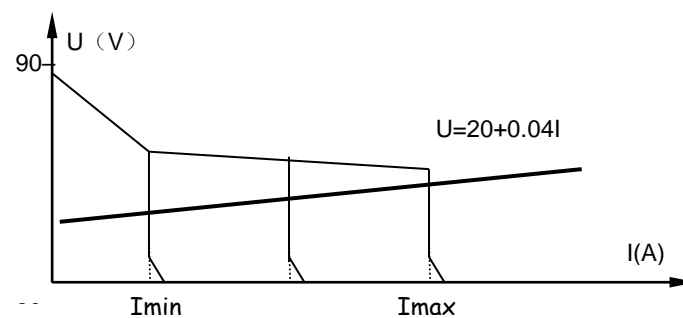

Figure 2: Volt-Ampere curve

**1. Main technical parameters**

Description	Parameters		
	ARC315E	ARC400E	ARC500E
Rated input voltage	3 phase 380V±10%/50Hz		
Rated output capacity	10.3KW	14.4KW	20KW
Rated input current	21A	28A	38A
Rated duty cycle	60%		
Range of output current	20 ~ 315A	20 ~ 400A	20 ~ 500A
Rated open load voltage	70V	70V	82V
Full-load efficiency	89%		
Power factor ( full-load )	0.95		
Welding electrode diameter	2 ~ 5mm	2 ~ 6mm	2 ~ 6mm
Weight	29Kg	29Kg	30Kg
Dimension	501×232×495 mm		
Insulation grade	H/B		

Table1: Parameter Specification

## 2. Main circuit diagram

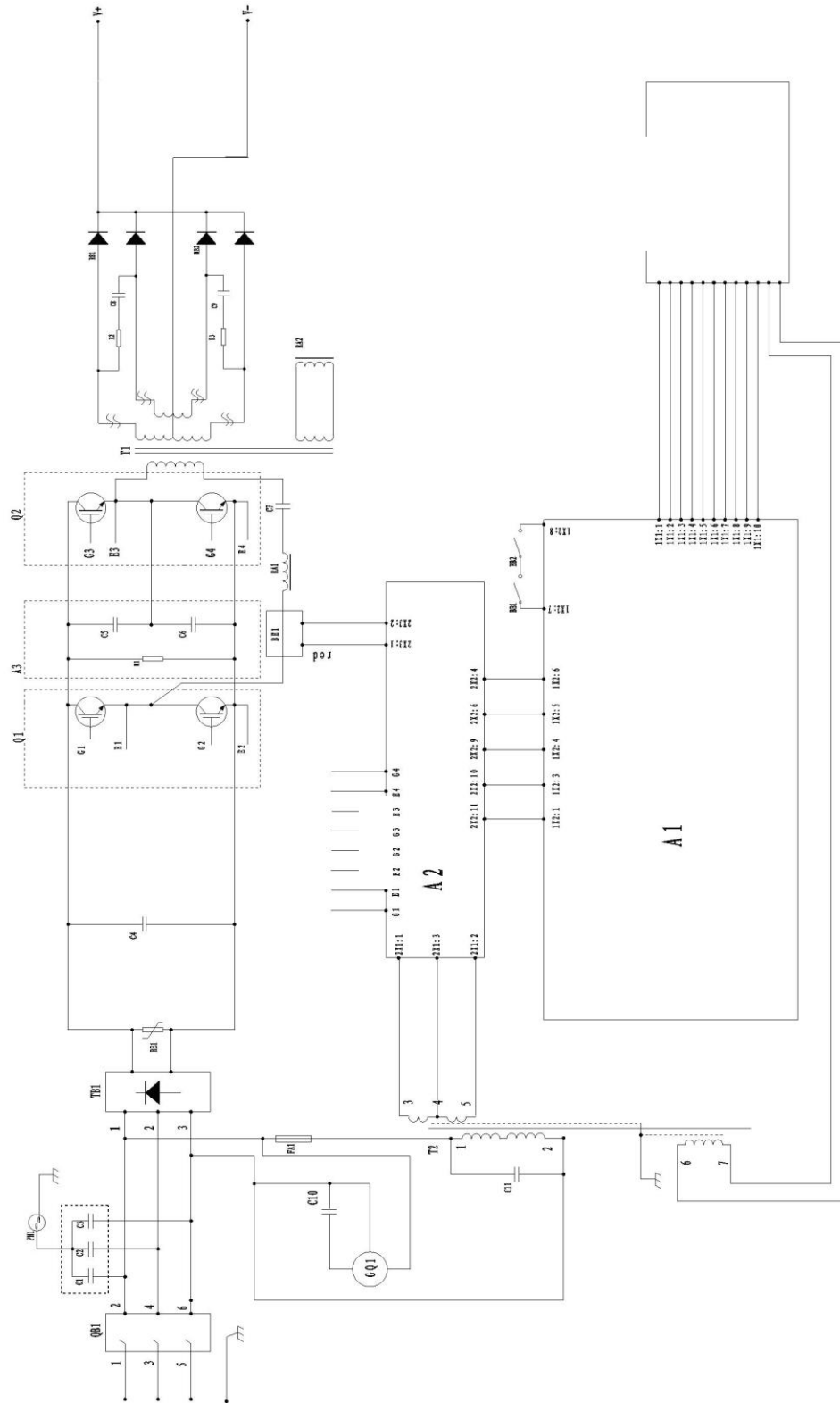

Figure 3: Main Circuit Diagram

### 3. Components List

● ARC315E /400E

No.	Tab	Item	Stock No.	Quantity
1	QB1	Circuit breaker	745011-00049	1
2	C1~C3	Polypropylene capacitor	722001-00023	3
3	Q1、Q2	IGBT module	735007-00046	2
4	TB1	3-phase rectifier module (small)	735005-00009	1
5	RE1	Varistor	720021-00017	1
6	C4	Polypropylene capacitor	722001-00070	1
7	A3	IGBT protection board	220005-00056	1
8	BE1	Power Inductor	220149-00070	1
9	RA1	Resonance Inductor	220521-00037	1
10	C7	Polypropylene capacitor	722001-00073	1
11	T1	Main transformer	220629-00090	1
12	RA2	Current exchange inductor	220281-00021	1
13	RB1、RB2	Fast recovery diode module	735006-00027	2
14	GQ1	Fan	746001-00011	1
15	FA1	Fuse	745007-00012	1
16	T2	Transformer for ZKB/QDB	763001-00136	1
17	A1	Main control board	210580-00362	1
18	A2	Drive board	210310-00069	1
19	BB1	Thermal	745008-00006	1
20	BB2	Thermal	745008-00008	1
21		Digital displayer	755001-00003	1
22		Potentiometer	720031-00030	1
23		Potentiometer	720031-00042	2

Table 2: Components List for ARC315E/400E

## ● ARC500E

No.	Tab	Item	Stock No.	Quantity
1	QB1	Circuit breaker	745011-00050	1
2	C1~C3	Polypropylene capacitor	722001-00023	3
3	Q1、Q2	IGBT module	735007-00068	2
4	TB1	3-phase rectifier module (small)	735005-00010	1
5	RE1	Varistor	720021-00017	1
6	C4	Polypropylene capacitor	722001-00070	1
7	A3	IGBT protection board	220005-00057	1
8	BE1	Power Inductor	220149-00071	1
9	RA1	Resonance Inductor	220521-00037	1
10	C8	Polypropylene capacitor	722001-00073	1
11	T1	Main transformer	220629-00103	1
12	RA2	Current exchange inductor	220281-00021	1
13	RB1、RB2	Fast recovery diode module	735006-00029	2
14	GQ1	Fan (1-phase 380V)	746001-00017	1
15	FA1	Fuse	745007-00012	1
16	T2	Transformer for ZKB/QDB	763001-00113	1
17	A1	Main control board	210580-00370	1
18	A2	Drive board	210310-00069	1
19	BB1	Thermal	745008-00006	1
20	BB2	Thermal	745008-00008	1
21		Digital displayer	755001-00003	1
22		Potentiometer	720031-00042	2
23		Potentiometer	720031-00030	1

Table 3: Components List for ARC500E

## Features & Applications

ARC-E series inverter arc welding machines are manufactured in line with the following standards: GB15579, 1-2004 “ARC Welding Equipments· Part One· Power Source”.

This series machines are SMAW machines with different specifications of rated current: 315A, 400A, 500A, which are novelty high-efficient and energy-saving DC Arc welders, not only are used in carbon steel and low alloy steel welding, but also used in stainless steel, high alloy steel, copper, silver, molybdenum and titanium welding.

### Features and Benefits:

- High duty cycle. Small size, light weight.
- Welding current can be adjustable in very wide range.
- Low welding spatter.
- Easy to arc-starting and molten pool control
- Digital display for accurate parameter preset.
- Soft switch technology, high efficiency.

### Applications:

- Shipbuilding and offshore engineering
- Maintenance and repair
- Industry plant construction
- Pipeline industry



## **1. Pre-installation**

### **1.1 Installation Environment**

**The ARC-E series is designed for use in adverse environments. Examples of environments with increased adverse conditions are:**

- In locations in which freedom of movement is restricted, so that the operator is forced to perform the work in a cramped (kneeling, sitting or lying) position with physical contact with conductive parts;
- In locations which are fully or partially limited by conductive elements, and in which there is a high risk of unavoidable or accidental contact by the operator;
- In wet or damp hot locations where humidity or perspiration considerably reduces the skin resistance of the human body and the insulation properties of accessories.
- Environments with adverse conditions do not include places where electrically conductive parts, in the near vicinity of the operator, which can cause increased hazard, have been insulated.
- The gradient of ground must be no more than 10°
- Ensure no wind at the welding position, or use screen to block the wind.
- When using water-cooled torch, must be care of not being frozen.
- Welding power sources with degree of protection IP21S may be stored, but are not intended to be used outside during precipitation unless sheltered.

### **1.2. Installation Location**

**Be sure to locate the welder according to the following guidelines:**

- In areas, free from moisture and dust.
- Ambient temperature between 0 degrees C to 40 degrees C.
- In areas, free from oil, steam and corrosive gases.
- In areas, not subjected to abnormal vibration or shock.
- In areas, not exposed to direct sunlight or rain.
- Place at a distance of 12" (304.79mm) or more from walls or similar boundaries that could restrict natural airflow for cooling.

### 1.3 Power Source Connections

#### Warning

**Thermal Arc advises that this equipment be electrically connected by a qualified electrician. ELECTRIC SHOCK can kill; SIGNIFICANT DC VOLTAGE is present after removal of input power.**

#### DO NOT TOUCH live electrical parts.

- SHUT DOWN welding power source, disconnect input power employing lockout/tagging procedures.
- Lockout/tagging procedures consist of padlocking line disconnect switch in open position.
- Removing fuses from fuse box, or shutting off and red-tagging circuit breaker or other disconnecting device.

### 1.4. Power Supply Requirements

- Input volt must be standard sine wave, effective value 380V, 50Hz.
- Unbalance degree of 3- phase volt must be no more than 5%.
- Power supply:

Product model		ARC315E	ARC400E	ARC500E
Power supply		3 phase AC 380V		
Min. power capacity		21KVA	28KVA	38KVA
Input protection	Fuse	40A	50A	63A
	Breaker	63A	63A	100A
Min. Cable size	Input side	2.5mm <sup>2</sup>	2.5mm <sup>2</sup>	4mm <sup>2</sup>
	Output side	35mm <sup>2</sup>	50mm <sup>2</sup>	70mm <sup>2</sup>
	Earth lead	2.5mm <sup>2</sup>	2.5mm <sup>2</sup>	4mm <sup>2</sup>

Table 4: Power supply connection

Note: The size of fuse and breaker in the table are for reference only.

## 2. Installation

The machines are portably designed, can be effortlessly moved by operators without fix-up. But it should be settled in even and dry places with well ventilation.

- (1) Ensure the welding cable be connected to the power source firmly.
- (2) Adjust every knobs, and switches on the front panel to proper position in line with selected mode.
- (3) Turn on the circuit breaker on the power source.
- (4) Connect input 3 phase primary power cable to switch box.

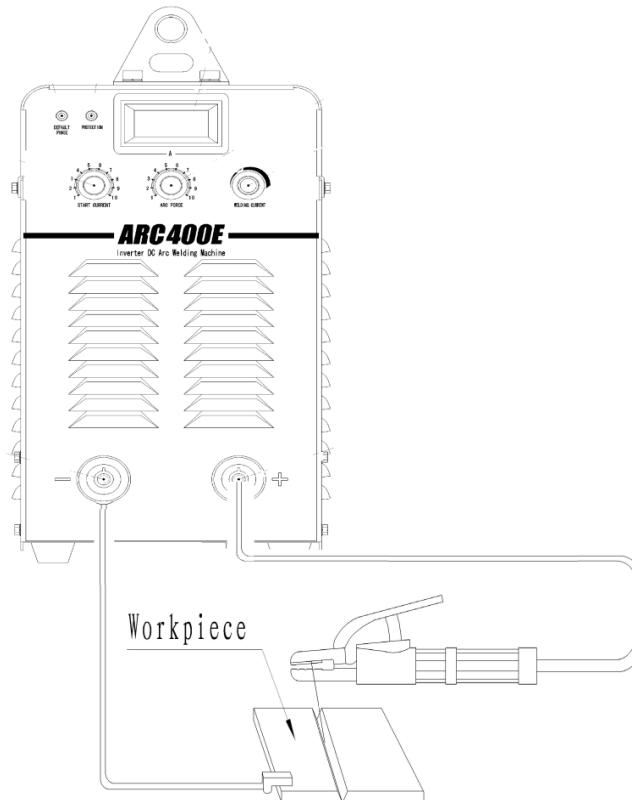

Figure 4: Outside connection diagram of ARC-E series

***Attention: Before you plug the welding cable, please turn off the power and rightly calibrate the plug key to the socket slot at first, then insert and turn the plug clockwise until it firmly seated. Make sure the plug and the socket are well-connected to be sound conductivity in case that they are burnt out by over resistance heat.***

## Operating Instruction

### 1. Functional introduction

#### 1.1 Front panel illustration and parts number reference

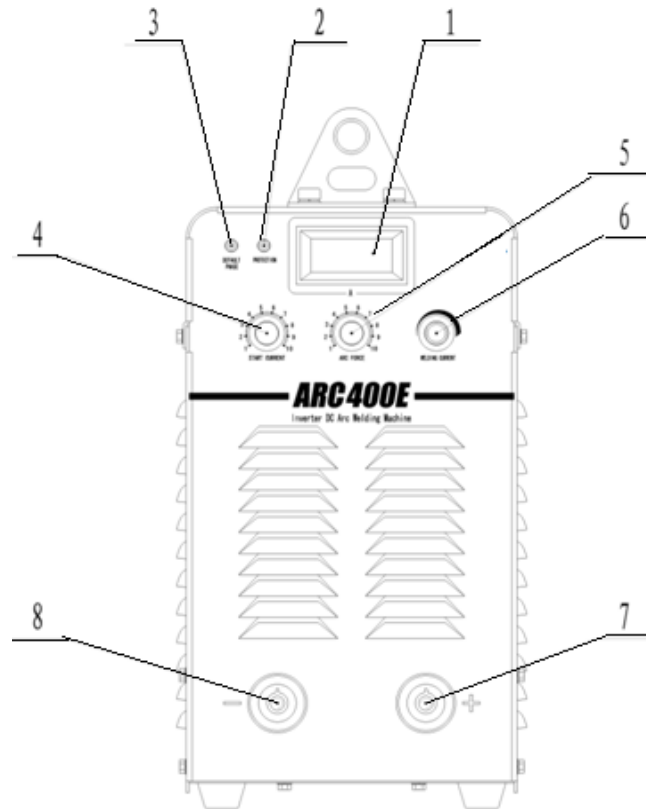

Figure 5: Front Panel

(1) Amp LCD

(2) Protection on LED

Welding machine will automatically stop working when it is overheat, and the LED will be light up.

(3) Default Phase on LED

It indicates whether the input voltage is phase missing, if default phase, the LED will be light up.

(4) Arc-starting current regulation knob

Used to adjust the arc-starting current

(5) Arc force current regulation knob

Used to adjust arc force current

## (6) Welding current regulation knob

Used to adjust welding current on panel

## (7) Welding cable (+) quick socket

Connect to electrode holder.

## (8) Welding cable (-) quick socket

Connect to workpiece.

## 1.2 The rear panel and parts number reference

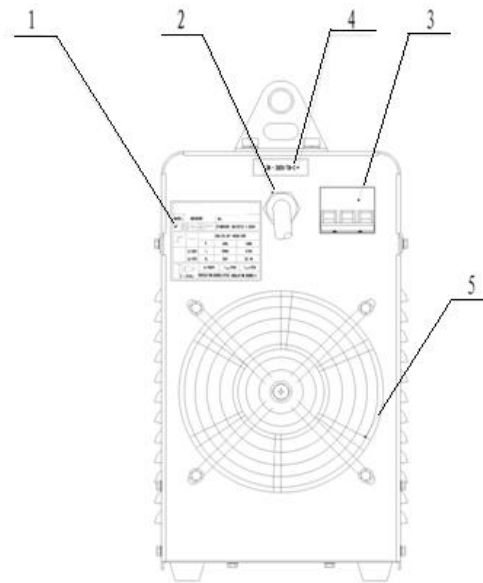

Figure 6: Rear panel

## (1) Specification plate

## (2) Input power cable

It is 4-pin cable. The mixed-colored wire must be firmly grounded, the rest wires connect to corresponding 3-phase power supply.

## (3) Circuit breaker

The function of circuit breaker is to protect welding machine by automatic trip to turn-off power supply while in machine overload or failure. Normally, the switch flipped to upward means power-on. Use switch on the switch box to start or stop welding machine. Don't use this air switch as power switch.

## (4) Input warning mark

## (5) Cooling fan

## 2. Operating instruction

Turn on the air switch on the switch box, the “Normal” indication lamp will light on and cooling fan rotates. Before welding normally, set up parameters by adjusting knobs and switches on the front panel according to the selected mode.

Customer should refer to parameters defined in table 5 showing below:

Work piece thickness( mm )	< 1	2	3	4 ~ 5	6 ~ 12	≥13
Electrode diameter ( mm )	1.5	2	3.2	3.2 ~ 4	4 ~ 5	5 ~ 6
Welding current ( A )	20 ~ 40	40 ~ 50	90 ~ 110	90 ~ 130	160 ~ 250	250 ~ 400

Table 5: SMAW welding parameters

## Repair & Maintenance

***WARNING: Have a qualified electrician do the maintenance and trouble shooting work. Turn the input power off, using the disconnect switch at the fuse box before working inside the machine.***

### 1. Cautions

- Rivet equipment name tag on the specified area of the case, otherwise the inside parts will possibly be damaged.
- Connect welding cable to terminals firmly, otherwise the terminals will be burn out which will cause the instability of welding process.
- Avoid welding cable and control cable being broken, and prevent welding machine from being short circuit.
- Never let welding machine be bumped into or stacked up by heavy objects.
- Ensure good ventilation
- Under high temperature, if work with large current for long period, welder may shut down automatically due to thermal protection acts. At this point, let the machine runs under open-load for a few minutes, and it will be automatically recover.
- Under high temperature, if work with large current for long period, welder may shut down automatically due to air switcher trips. Cut off the power supply to the electricity switchboard on frame, and wait for 5 minutes to turn on the circuit breaker on the power source fist then connect the power supply to the electricity switchboard on frame. And leave the machine runs under open-load condition for a while.
- After welding, cut off power supply.

### 2. General maintenance

- Remove dust from power resource with pressure air by qualified individuals every 3-6 months. Check if the jointers are loose.
- Check regularly if cables are worn out, knobs are loose, and components of panel are damaged.
- Check regularly if cables are tightly connected to cable connecting terminals in case of terminals being burnt out.

### 3. Procedure for regular checking prior to maintenance

- Check if all front panel switches are on the proper positions.

- Check if the input volt has the phase missing, and range are between 340~420V.
- Check if the input cable is connected correctly and firmly with the power source.
- Check if the welding cables are connected correctly and firmly.

**WARNING: Have a qualified electrician do the maintenance and trouble shooting work. Turn the input power off, using the disconnect switch at the fuse box before working inside the machine. Don't open up case uninstructed, the max volt inside machine is 600V, Never discharge high voltage to welder case with welding torch! Shut down power source before changing or repairing welding cable or torch**

№	TROUBLE	CAUSES	WHAT TO DO
1	After power on, the machine does not work.	(1) Phase missing in power source (2) Fuse( 2A )in welder is broken. (3) Cable is broken	(1) Check power source (2) Check if cooling fan, transformer for ZKB/QDB and main control board are good or not. (3) Check connection
2	Circuit breaker on back panel trips while the machine is working normally.	(1) The following components may be damaged: IGBT module, 3-phase rectify module, outputting diode module, or other components (2) Drive board is damaged. (3) Short circuit between lines.	(1) Check and replace. (2) When IGBT module is damaged.
3	Welding current is unstable.	(1) Phase missing (2) The following components may be damaged: Potentiometers, switches on front panel. (3) Main control board is damaged	(1) Check power source. (2) Check and replace.
4	Welding current is not adjustable.	(1) Potentiometer of welding current adjustment is damaged. (2) Main control board is damaged.	Check and replace.

Table 6: Trouble Shooting Table



## **1. General**

The user is responsible for installing and using the arc welding equipment according to the manufacturer's instructions. If electromagnetic disturbances are detected, then it shall be the responsibility of the user of the arc welding equipment to resolve the situation with the technical assistance of the manufacturer. In some cases this remedial action may be as simple as earthing the welding circuit, see note. In other cases it could involve constructing an electromagnetic screen enclosing the welding power source and the work complete with associated input filters. In all cases electromagnetic disturbances shall be reduced to the point, where they are no longer troublesome.

***NOTE: The welding circuit may not be earthed for safety reasons. Changing the earthing arrangements should only be authorized by a person who is competent to assess whether the changes will increase the risk of injury.***

## **2. Assessment of area**

Before installing arc welding equipment the user shall make an assessment of potential electromagnetic problems in the surrounding area. The following shall be taken into account:

- 1) Other supply cables, control cables, signaling and telephone cables, above, below and adjacent to the arc welding equipment;
- 2) Radio and television transmitters and receivers;
- 3) Computer and other control equipment;
- 4) Safety critical equipment, for example guarding of industrial equipment;
- 5) The health of the people around, for example the use of pacemakers and hearing aids;
- 6) Equipment used for calibration or measurement;
- 7) The immunity of other equipment in the environment is compatible. The user shall ensure that other equipment being used in the environment is compatible. This may require additional protection measures;
- 8) The time of day that welding or other activities are to be carried out.

### 3. Methods of reducing emissions

#### 1) Public supply system

Arc welding equipment should be connected to the public supply system according to the manufacturer's recommendations. If interference occurs, it may be necessary to take additional precautions such as filtering of the public supply system. Consideration should be given to shielding the supply cable of permanently installed arc welding equipment, in metallic conduit or equivalent. Shielding should be electrically continuous its length. The shielding should be connected to the welding power source so that good electrical contact is maintained between the conduit and the welding power source enclosure.

#### 2) Maintenance of the arc welding equipment

The arc welding equipment should be routinely maintained according to the manufacturer's recommendations. All access and service doors and covers should be closed and properly fastened when the arc welding equipment is in operation. The arc welding equipment should not be modified in any way, except for those changes and adjustments covered in the manufacturer's instructions. In particular, the spark gaps of arc striking and stabilizing devices should be adjusted and maintained according to the manufacturer's recommendations.

#### 3) Welding cables

The welding cables should be kept as short as possible and should be positioned close together, running at or close to the floor level.

#### 4) Equipotent bonding

Bonding of all metallic components in the welding installation and adjacent to it should be considered. However, metallic components bonded to the work piece will increase the risk that the operator could receive an electric shock by touching these metallic components and the electrode at the same time. The operator should be insulated from all such bonded metallic components.

#### 5) Earthling of the work piece

Where the work piece is not bonded to earth for electrical safety, nor connected to earth because of its size and position, for example ships hull or building steelwork, a connection bonding the work piece to earth may reduce emissions in some, but not all instances. Care should be taken to prevent the earthling of the work piece increasing the risk of injury to users, or damage to other electrical equipment. Where necessary, the connection of the work piece to earth should be made by a direct connection to the work piece, but in some countries where direct connection is not permitted, the

bonding should be achieved by suitable capacitance, selected according to national regulations.

6) Screening and shielding

Selective screening and shielding of other cables and equipment in the surrounding area may alleviate problems of interference. Screening of the entire welding installation may be considered for special applications.

**Appendix B****Feedback Form**

Name of Company			
Address			
Contact person		Title	
Telephone No		Fax No.	
Email Address			
Company's filed of business			
Comments :			

Thank you for taking the time to share your feedback. Your comments and suggestions will help us to serve you better.